

Snow Pusher Skid-Steer Mount

Specifications

Model	Weight (Approx.)
SPSS-0636	1,100 Lbs.
SPSS-0836	1,200 Lbs.
SPSS-1036	1,300 Lbs.
SPSS-1236	1,430 Lbs.

Construction

Main Push Plate	3/16" x 36"
Side Plates	3/4" x 36" x 36"
Integrated Bucket Mounts	3/8" Plate
Quick-Attach Mount	3/8" Plate
Edge Mounting Bracket	4" x 4" x 3/8" Struct. Angle
Horizontal Mid Brace	6" Struct. Channel
Horizontal Top Brace	4" Struct. Channel
Cutting Edge	1 1/2" x 10" Rubber
Rubber Hold Down	3/8" with 3/4" Bolts
Skid Shoes	1" AR450
Skid Mount Plate	3/8" with 3/4" Bolts

All Specifications are subject to change without notice.

Standard Features

- Full Weld Construction
- Adjustable & Reversible Rubber Cutting Edge

Available Options

- Steel Cutting Edge
- Customized Mounts

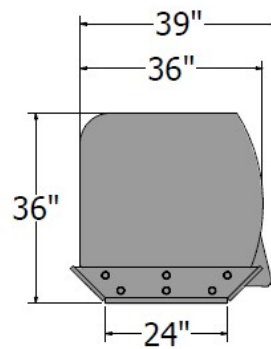
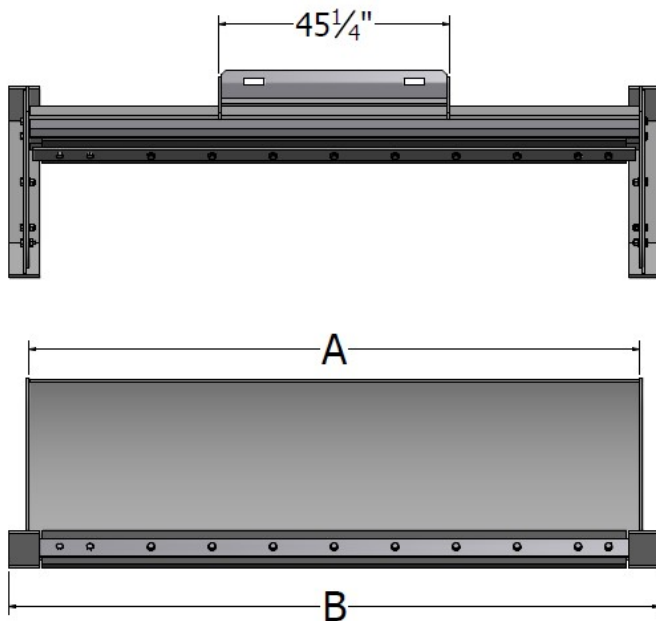
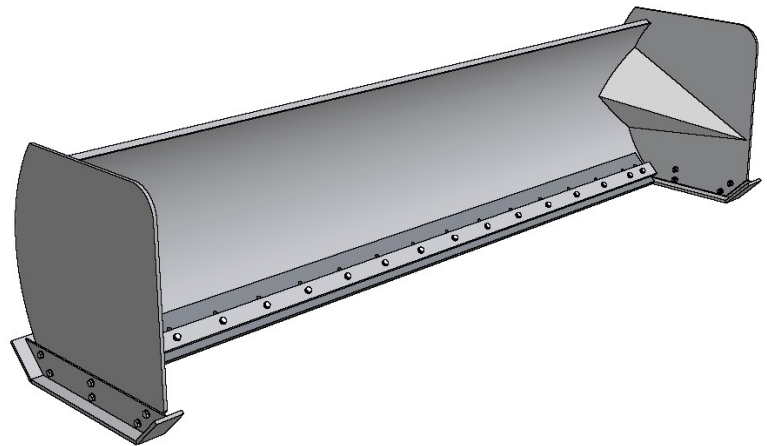

Illustration for reference only

Model	A	B
SPSS-0636	6'-0"	6' 8"
SPSS-0836	8'-0"	8' 8"
SPSS-1036	10'-0"	10' 8"
SPSS-1236	12'-0"	12' 8"



Distributor

385 Sumpter Road • Belleville • MI 48111-2932 • Phone (734) 699-5561 • Fax (734) 699-0360

P.O. Box 68 • Belleville • MI 48112-0068

On the Web at: <http://www.contractwelding.com>

2/17 REV 2